



# Certificate of Accreditation

## On-Site Wastewater Management System

This Certificate of Accreditation is hereby issued by the Director of Building Control pursuant to Section 18(1) of the *Building Act 2016* (accreditation of products).

<b>System:</b>	Econocycle Models: Eco Pro a) Concrete (10EP) and b) Poly (10EP)
<b>Manufacturer or Supplier:</b>	Eco-Septic Pty Ltd, Trading as Econocycle
<b>Of:</b>	15 Econo Place, Silverdale NSW 2753

This is to certify that the Econocycle Models: Eco Pro System as described in Schedule 1, is accredited as an AWTS for use in plumbing installations in Tasmania for single dwellings. This accreditation is subject to the conditions and permitted uses specified in Schedule 2, and the National Construction Code.

**Peter John Graham**  
**Director of Building Control**  
Consumer, Building and Occupational Services  
Department of Justice

**Date of Issue:** 24 December 2020

**Certificate Number:** DOC/20/108273

This Certificate of Accreditation is in force until 24 December 2025, unless withdrawn earlier at the discretion of the Director of Building Control

## Document Development History

<b>Version</b>	<b>Date</b>	<b>Application date</b>	<b>Sections amended</b>
1.0	24/12/2020	New Models to AS1546.3:2017 Secondary Treatment System	Original release
1.1	23/03/2021	Address Correction	Cover Page

# Schedule I: Specification

## General Description

The Econocycle model Eco Pro Aerated Wastewater Treatment System (AWTS) is designed to treat the wastewater from a residential dwelling occupied by a maximum of 10 persons. The Econocycle model Econo Pro AWTS is contained in one vertical axis type cylindrical precast concrete collection well with a design capacity of 8,004 litres. The operational water level in the aeration chamber of the system is 1,430 mm.

The system consists of:

- A primary sedimentation chamber
- A contact aeration chamber
- A sedimentation/clarifying chamber.
- A Chlorine Contact & Pump Out Chamber.
- Air is supplied to the contact aeration chamber by an air blower with an output of 80 litres/minute at 1.5 m water depth.
- A submersible irrigation pump head of 6 metre head or better.

The Econocycle system works on the combined principles of primary settling followed by aerobic treatment and disinfection. All household wastewater enters the tank through the inlet (shown on the left hand side of the diagram below) and settles into the septic zone.

Towards the top of the baffle wall which separates the septic and aeration compartments, there is an outlet which enables the primary treated effluent to trickle into the aeration zone. From this point the effluent is filtered over the growth media plates further breaking down the wastewater.

Once the organic matter has been absorbed within the aerobic (aeration) zone the wastewater passes to the clarification zone (secondary sedimentation process). At this stage the wastewater should be clear and odourless.

Before the treated wastewater is released from the clarification chamber it is circulated through the chlorinator for disinfection. The disinfected wastewater has a free residual chlorine concentration equal to or greater than 0.5 mg/L but not greater than 2.0 mg/L. Chlorine tablets are replenished at quarterly service intervals.

The Econocycle Models: Eco Pro a) Concrete (10EP) and b) Poly (10EP) are designed to treat the wastewater from a residential dwelling up to 1,500 Litres per day or 10 Equivalent Persons (10EP) The Econocycle are each contained in one vertical axis type cylindrical collection well.

Both models have been assessed as Advanced Secondary Treatment Systems in AS/NZS 1546.3:2017.

For treatment system schematic drawings and flow path, refer to Appendix A.

For Engineering drawings refer to Appendix B.

## Tank and Chamber Capacities

	<u>Polymer</u>	<u>Concrete</u>	<u>Difference</u>	
Segment	Working Capacity	Working Capacity	Working Capacity	<u>% of Concrete tested tank</u>
Primary A	1,996 Litres	2,000 Litres	-4 Litres	99.8%
Primary B	996 Litres	1,000 Litres	-4 Litres	99.6%
Aeration	2196 Litres	2,231 Litres	-37 Litres	98.4%
Clarification (Sedimentation)	462 Litres	465 Litres	-3 Litres	99.3%
Disinfection and Pump out	462 Litres	370 Litres	*92 Litres	124.9%
<b>Total</b>	<b>6,112 Litres</b>	<b>6,066 Litres</b>	<b>+46 Litres</b>	<b>N/A</b>
<b>Emergency Storage without Contamination</b>	<b>1,076Litres</b>	<b>1976 Litres</b>	<b>-900 Litres</b>	<b>&lt;1000Litres</b>
<b>Total tank capacity</b>	<b>7188 Litres</b>	<b>8042 litres</b>	<b>-854 Litres</b>	<b>N/A</b>

The Econocycle Poly 1500 is within 5% of the volumes of the Concrete system where the volume is lower. The sizes are relatively the same in each segment. Therefore the Poly version is very close to the concrete version in working capacities for each chamber. Therefore, the unit is expected to perform in an identical manner to the concrete version of the system

## Schedule 2: Conditions of Accreditation

### 1.0 Definitions

In this schedule:

**AS/NZS 1547** means the Joint Australian/New Zealand Standard 'AS/NZS 1547:2008 On-site domestic-wastewater management'

**AS/NZS 1546.3** means the Joint Australian/New Zealand Standard 'AS/NZS 1546.3:2017 On-site domestic wastewater treatment systems, Part 3: Secondary treatment systems'

**AS/NZS 3000** means the Joint Australian/New Zealand Standard 'AS/NZS 3000 Wiring rules'

**AS/NZS 5667** means the Joint Australian/New Zealand Standard 'AS/NZS 5667.1:1998 Water quality – Sampling, Part 1: Guidance on the design of sampling programs, sampling techniques and preservation and handling of samples'

**AWTS** means Aerated Wastewater Treatment System. A system which uses the processes of aeration followed by clarification to achieve biological treatment of wastewater

**BOD<sub>5</sub>** means '5-day Biochemical Oxygen Demand'

**Council** means 'the Municipal Council having jurisdiction'

**Commissioned** means 'when the test results from a NATA Certified Laboratory show that the water quality requirements for the AWTS have been met and all pre-commissioning tests have been carried out in accordance with AS/NZS 1547 on all associated equipment and the sub-surface irrigation system' (where installed)

**Designer** means 'a person who has a specialty in the area of designing on-site waste water management system installations and may include but not be restricted to appropriately trained professional engineers, soil scientists, land surveyors and plumbers'

**Director** means 'the Director of Building Control'

**E. coli** means 'Escherichia coli of the family Enterobacteriaceae which is a bacterium used in public health as an indicator of faecal pollution'

**g/m<sup>3</sup>** means grams per cubic metre

**Manufacturer** means 'ECO-Septic Pty Ltd trading as Econocycle;'

**N** means 'Nitrogen'

**NATA** means 'National Association of Testing Authorities'

**PCA** means 'Plumbing Code of Australia 2019'

**Permit** means 'a Permit issued by the council pursuant to 'Part 12 of the Building Act 2016'

**Permit authority** means 'a person or body authorised for that purpose by the council of the municipal area in which the on-site waste water management system is installed'

**Supplier** means 'the party that is responsible for ensuring that products meet and, if applicable, continue to meet, the requirements on which the certification is based.' The supplier for the system is **ECO-Septic Pty Ltd trading as Econocycle;**

System means Econocycle AWTS Models: Eco Pro a) Concrete and b) Poly

**TSS** means 'Total Suspended Solids'.

## 2.0 General

- 2.1 This Certificate of Accreditation is valid up until the date nominated on the front page of this accreditation. Any application for variation or renewal must be accompanied by Product Certification to AS/NZS 1546.3 that has been issued by a JAS-ANZ accredited Conformity Assessment Body (CAB) and other required documentation in accordance with the latest Application for Accreditation Form. The Certificate of Accreditation may be withdrawn by the Director at any time and is not transferable
- 2.2 This certificate supersedes all previously issued certificates.
- 2.3 The *system* must be supplied, constructed and installed in accordance with the design submitted and accredited by the *Director*.
- 2.4 The *system* must not be installed in a plumbing installation other than in accordance with the conditions of permit issued by the *Permit Authority*.
- 2.5 Each *system* must be permanently and legibly marked on a non-corrosive metal plaque or equivalent, attached to the lid with the following information:
- The brand and model name or designation of the system
  - The manufacturer's name or registered trademark
  - Top load limitations, and
  - The month and year of manufacture.
- 2.6 The *supplier* must supply the owner and occupier, of each installation, with a user manual setting out the following:
1. the treatment process
  2. procedures to be followed in the event of a system failure
  3. emergency contact number
  4. care, operation, monitoring and maintenance requirements, and
  5. inspection and sampling procedures to be followed as part of the on-going monitoring and program required by the permit authority.
- 2.7 Any proposed modifications to the *system's* specified processes, equipment, materials, fittings or manuals must have prior authorisation in writing from the *Director* and may be subject to additional verification or testing.
- 2.8 Each application to a *permit authority* to install a *system* must be accompanied by a site-and-soil evaluation report and design report in accordance with AS/NZS 1547 as appropriate.
- 2.9 The *supplier* must provide the following information to each *permit authority* where it is intended to install a *system* in their jurisdiction:
- Statement of warranty
  - Statement of service life
  - Quality Assurance Certification
  - Installation Manual
  - Service Manual
  - Owner's Manual
  - Service Report Form
  - Engineering Drawings on A3 format
  - Detailed Specifications
  - Certificate of Accreditation and Schedules.
- 2.10 This Certificate of Accreditation is valid for five (5) years from the date of issue or until withdrawn by the *Director*.

- 2.11 At each anniversary of the accreditation date the *supplier* must submit to the *Director* a list of all *systems* installed in Tasmania during the previous 12 months. The *Director* may randomly select up to 10% of the installed *systems* in any one calendar year. The *Director* will nominate a NATA accredited laboratory for all sampling and will be tested for BOD<sub>5</sub> and TSS and Chlorine residual. The sampling and testing of the selected *systems* is to be done at the *supplier's* expense. The following results must be reported to the *Director*:
- Address of premises
  - Date inspected and sampled
  - Sample identification number
  - Chlorine Residual
  - BOD<sub>5</sub>
  - TSS, and
  - Service history.
- 2.12 Where a *system* has been found not to operate satisfactorily during its serviceable life, and as a result require modification to achieve the required water quality limits, all installed *systems* are to be modified accordingly.
- 2.13 When granting a *permit* the *permit authority* is to satisfy itself that the *designer's* choice of the *system* configuration is optimal for the proposed use and site conditions.
- 2.14 The *system* must not be deployed to areas where seasonal climatic conditions will negatively affect its proper operation (refer to *manufacturer's* specifications).
- 2.15 Prior to the granting of a *permit* to install a *system* the following reports (see AS/NZS 1547 Clause 7.4) must be submitted with an application to the *permit authority*.

### **Site-and-soil evaluation report**

The site and soil evaluation report is to detail results of an assessment of the individual lot(s) for the public health, environmental, legal and economic factors which are likely to impinge on the location and design of a land-application. (Refer to AS/NZS 1547 Clause 5.2.4 and Appendices B, C, D, E & G).

### **Design report**

The Design Report is to include the following:

- (a) Relevant aspects of the site-and-soil evaluation report.
- (b) A report on the selection of the land-application. (Refer to AS/NZS 1547, Clause 5.5.7).
- (c) A report on the selection of the wastewater-treatment system. (Refer to AS/NZS 1547 Clause 5.2.4 and Appendices B, C, D, E & G).
- (d) Sufficient information to show that the relevant performance requirements set out in the PCA have been met.
- (e) A loading certificate which sets out the design criteria and the limitations associated with use of the system and incorporates such matters as:
  - (i) System capacity ((number of persons (EP) and daily flow)
  - (ii) Summary of design criteria
  - (iii) The location of and use of reserve areas
  - (iv) Use of water efficient fittings, fixtures, or appliances
  - (v) Allowable variation from design flows (peak loading events)
  - (vi) Consequences of changes in loading (due to varying wastewater characteristics)
  - (vii) Consequences of overloading the system

- (viii) Consequences of underloading the system
- (ix) Consequences of lack of operation, maintenance and monitoring attention, and
- (x) Any other relevant considerations related to the use of the system.

2.16 The following reports must be submitted to the *permit authority* and owner and be made available to the *Director* upon request after *commissioning* of the *system*:

#### **Installation and commissioning report**

The Installation and Commissioning Report is to cover the 'as-constructed' records of the *system* installation together with the results of *commissioning* tests to demonstrate correct construction and installation. The report is to be provided to the owner and *permit authority* on completion of the work. (Refer to and AS/NZS 1547 Clause 6.2.5.4).

#### **Inspection and Maintenance Report**

Maintenance reports cover ongoing inspection and maintenance operations in order to monitor the operation of the installation. ((Refer to AS/NZS 1547 Clause 6.3.5, Appendix T & U).

2.17 Where the supplied pump is not suitably rated for the proposed land application area it must be replaced with a pump which has a rated capacity that matches the hydraulic characteristics of the irrigation and be capable of discharging at least 50% more than the 30 minute flow rate. For drip irrigation, ensure that drip emitter flow rates do not vary more than 10% from the design rate over the whole of the system when installed on a sloping site.

**Note:** The pump selection is to be based on flow, head loss and pressure requirements.

2.18 Effluent distribution by sub-surface application may be permitted where the *Permit Authority* is satisfied that the application for a *permit* to install the *system* has demonstrated that the:

- (a) effluent can be retained within the authorised land application area
- (b) where applicable the land application has been designed and is capable of being installed and maintained in accordance with AS/NZS 1547
- (c) the location of the land application satisfies the relevant requirements of the State Policy on Water Quality Management 1997, and
- (d) the discharge is capable of satisfying the relevant water quality limits (see 5.2).

#### **Product approval documentation**

The following documents are referenced as part of this Accreditation:

<b>Document</b>	<b>Document date</b>
Global Certification Pty Ltd – Product Certificate of Registration No. 517 AS/NZS 1546.3:2017 Advanced Secondary 10 EP Level (Eco Pro AWTS)	3/11/2019
Global Certification Pty Ltd – Product Certificate Report of (Eco Pro AWTS) Concrete to AS/NZS 1546.3:2017 Report Number 517	3/11/2019
Global Certification Pty Ltd – Product of Conformance In-ground AS/NZS 1546.1:2008 Number 461 Steel Reinforced Concrete 8,042 Litres	14/12/2018
Global Certification Pty Ltd – Product Certificate Report of Eco Pro Poly to AS/NZS 1546.3:2017 Report Number 630	29/08/2020
Global Certification Pty Ltd – Product of Conformance In-ground AS/NZS 1546.1:2008 Number 630 Polyethylene Tank 7,188 Litres	29/08/2020



### 3.0 Installation and Commissioning

- 3.1 The installation and operation of the *system* must comply with the conditions of accreditation and the *manufacturer's* instructions.
- 3.2 All plumbing work carried out in connection with the *system* installation must satisfy the requirements of the *Building Act 2016* the NCC and the Tasmanian Plumbing Regulations and be carried out by a licensed plumber with appropriate training and qualifications.
- 3.3 All electrical work must be carried out by a licensed electrician and in accordance with relevant provisions of *AS/NZS 3000*.
- 3.4 The *system* requires a 240V AC power supply. A weather-proof isolating switch must be provided at the power outlet. The power supply must have its own clearly marked designated circuit breaker in the electricity supply fuse box.
- 3.5 Each *system* installation must be inspected and checked by the *designer* or the designer's agent. The *designer* on completion is to certify that the system has been constructed, installed and *commissioned* in accordance with its design, the conditions of accreditation and any additional requirements set out in the *permit*.

**Note:** Where the *designer* is not available to supervise the installation the *designer* should obtain signed certification from the installing plumber stating that the installation has been constructed/installed and *commissioned* in accordance with its design, the conditions of accreditation and any additional requirements of the *council* and/or *permit authority*.

- 3.6 A report is to be prepared by the installing plumbing contractor detailing the inspection of the installation and the results of the *commissioning* tests and be accompanied by a certificate certifying that the system is operating and performing adequately (see 2.16).
- 3.7 Copies of the following reports/certificates must be submitted to the *council* and the owner as soon as practicable after the commissioning of the *system* and after each scheduled or unscheduled service or inspection for the period specified in the *permit*:
  - (a) The initial plant installation and commissioning report
  - (b) All required laboratory analytical test reports, and
  - (c) All inspection and maintenance reports.
- 3.8 Copies of any report or certificate required by the conditions of accreditation must be made available to the *Director* on request.
- 3.9 The *designer* is to provide a statement warning the user of which items and products that must not be placed in, or used within the *system*.
- 3.10 To verify that the plant is commissioned, sampling must be carried out, by a *council* recorded Contractor, for *BOD<sub>5</sub>*, *TSS* and Free Residual Chlorine. The samples are to be tested and reported on by a NATA certified laboratory.

### 4.0 Maintenance and monitoring

- 4.1 Each installation must be serviced and monitored at not less than 3 monthly intervals in accordance with the conditions of accreditation, the conditions of *permit/maintenance* schedule and *manufacturer's* requirements.

**Notes:**

- (1) Only a licensed plumber can carry out the maintenance and required monitoring of the *system* other than electrical work unless licensed to do so.
  - (2) The licensed plumber may need to complete training by the *supplier* before carrying out any maintenance on the *system*.
  - (3) The maintenance and monitoring intervals may be combined provided the monitoring frequency remains at 3 month intervals.
- 4.2 The owner of the *system* must enter into and maintain a maintenance contract with a licensed plumbing wastewater servicing contractor and provide council with a copy of that contract.
- 4.3 The *system* must be operated and maintained to ensure it performs continuously and without any intervention between normal service intervals.
- 4.4 A service report is to be prepared by the plumbing contractor who carried out the service work detailing the inspection of the installation and the results of all servicing tests and conditions at the completion of all scheduled or unscheduled services or inspections.
- 4.5 The service report is to be accompanied by a signed certificate certifying that the *system* is operating and performing adequately.
- 4.6 A copy of the service report and certificate is to be provided to the occupant and *council*. Each service report is to contain a statement reminding the user of which items and products that must not be placed in the *system*.
- 4.7 Each service must include monitoring the operation of the *system* and associated land application.
- 4.8 Maintenance must be carried out on all mechanical, electrical and functioning components of the *system* as appropriate.
- 4.9 The monitoring, servicing and reporting of the installation must include but not be restricted to the following matters, as appropriate:
- (a) Reporting on weather conditions, ambient temperature, effluent temperature
  - (b) Odour
  - (c) Check and test pump
  - (d) Check and test air blower, fan or air venturi and clean/replace air filters
  - (e) Check and test alarm system
  - (f) Check slime growth on membranes and report the on condition of membranes
  - (g) Check and report operation of sludge return, sludge level and de-sludging;
  - (h) Check and record water meter reading (if fitted)
  - (i) Check and record operation of irrigation area, irrigation fittings
  - (j) Check and clean/replace irrigation filters
  - (k) Check and report on water quality (testing for pH, Turbidity, EC and dissolved oxygen)
  - (l) Check, and replenish chlorine disinfection system
  - (m) Cleaning of the following items at above the waterline:
    - (i) clarifier
    - (ii) pipework

- (iii) valves
- (iv) walls of chambers.

## 5.0 Performance

### 5.1 Hydraulic and Organic Loading:

The system is accredited for treatment of domestic wastewater as defined in ASI546.3:2017 clause 1.8.7 limited to IOEP with the following MAXIMUM hydraulic and organic loads:

Model	Hydraulic load (L/day)	Biochemical Oxygen Demand (g/day)
Eco Pro Concrete	1500	700
Eco Pro Poly	1500	700

### 5.2 Hydraulic and Organic Loading:

Treated effluent from the system must not exceed the following limits (90% of samples):

For sub-surface irrigation:	
5-day Biochemical Oxygen Demand (BOD <sub>5</sub> )	10 g/m <sup>3</sup> (max. 20 g/m <sup>3</sup> )
Total Suspended Solids (TSS)	10 g/m <sup>3</sup> (max. 20 g/m <sup>3</sup> )
For surface irrigation:	
5-day Biochemical Oxygen Demand (BOD <sub>5</sub> )	10 g/m <sup>3</sup> (max. 20 g/m <sup>3</sup> )
Total Suspended Solids (TSS)	10 g/m <sup>3</sup> (max. 20 g/m <sup>3</sup> )
E. coli	10 cfu/100 mL (max. 20 cfu/100 mL)
Free Residual Chlorine concentrations	≥ 0.5 g/m <sup>3</sup> and less than 2.0 g/m <sup>3</sup>

## 6.0 On-going management

- 6.1 The mandatory servicing and monitoring is to commence 3 months after the plant is *commissioned*. The servicing and monitoring is to coincide with the *supplier's* required on-going routine scheduled maintenance program.
- 6.2 In the event of failure to comply with the water quality limits set out in these conditions, fortnightly sampling and testing for *BOD<sub>5</sub>*, *TSS* and Free Residual Chlorine must be carried out until the plant is *re-commissioned*.
- 6.3 The method of preserving and the handling of samples taken from the plant must satisfy the relevant requirements of *AS/NZS 5667*.
- 6.4 Copies of the following reports and certificates must be submitted to the *permit authority* and the owner as soon as practicable after the *commissioning* of the *system* and after each scheduled or unscheduled service for the period specified in the *permit*:
  - the initial plant installation and *commissioning* report
  - all laboratory analytical test reports; and
  - all inspection and maintenance reports
- 6.5 The system is to be de-sludged strictly in accordance with the *manufacturer's* recommendations and the sludge is to be disposed of in accordance with the Tasmanian Biosolids Reuse Guidelines and the conditions of *permit*.
- 6.6 Only persons with a waste transport business Environment Protection Notice are to be engaged for the removal, transporting and disposal of accumulated sludge removed from the *system*.
- 6.7 Any waste material removed from the system must be collected and disposed of or utilised by an approved facility or agency.
- 6.8 Measures are to be put in place during servicing that will protect the environment, personnel and any other persons who could be affected by the activity.

## 7.0 Permitted uses

7.1 The effluent is suitable for land application by way of the following forms:

- (a) sub-surface by:
  - (i) subsurface drip irrigation in accordance with the relevant provisions of AS/NZS 1547
  - (ii) trenches, beds, mounds, evapo-transpiration in accordance with the relevant provisions of AS/NZS 1547.
- (b) above ground by:
  - (i) spray irrigation
  - (ii) surface drip irrigation in accordance with the relevant provisions of AS/NZS 1547.

**Note:** Each of the above forms of irrigation is subject to consent from the *permit authority* and the relevant provisions of AS/NZS 1547.

7.2 Where it is not practicable for effluent from the system to be applied in accordance with AS/NZS 1547 the method of discharge must satisfy contemporary relevant regulatory requirements to the satisfaction of the *permit authority*.

# Appendix A

## Schematic drawings

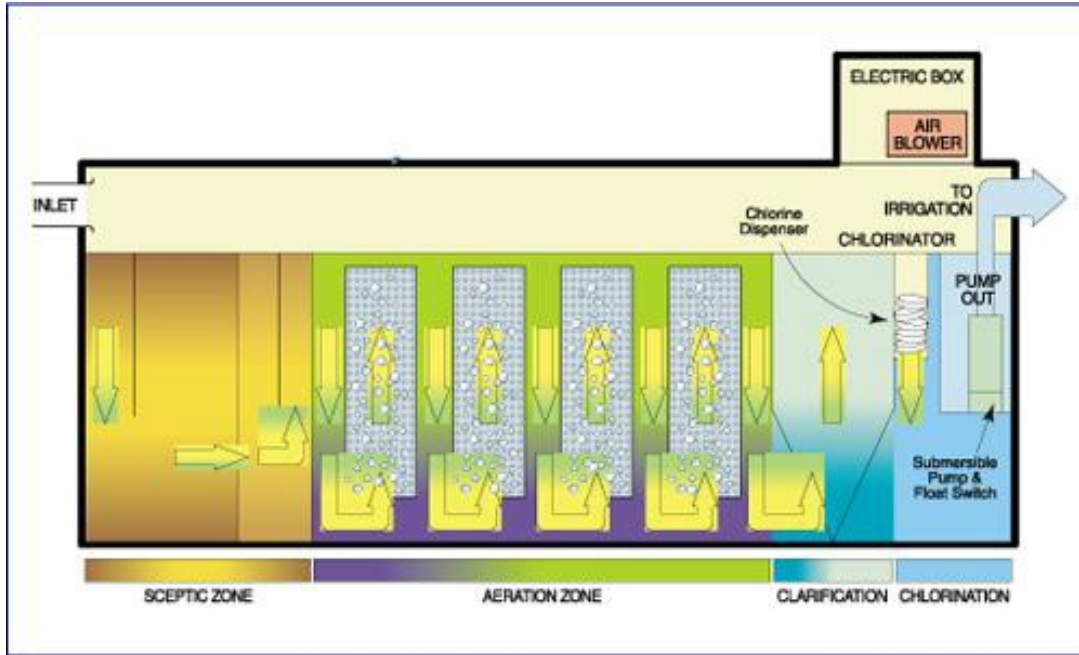

# Appendix B

## Engineering Drawings

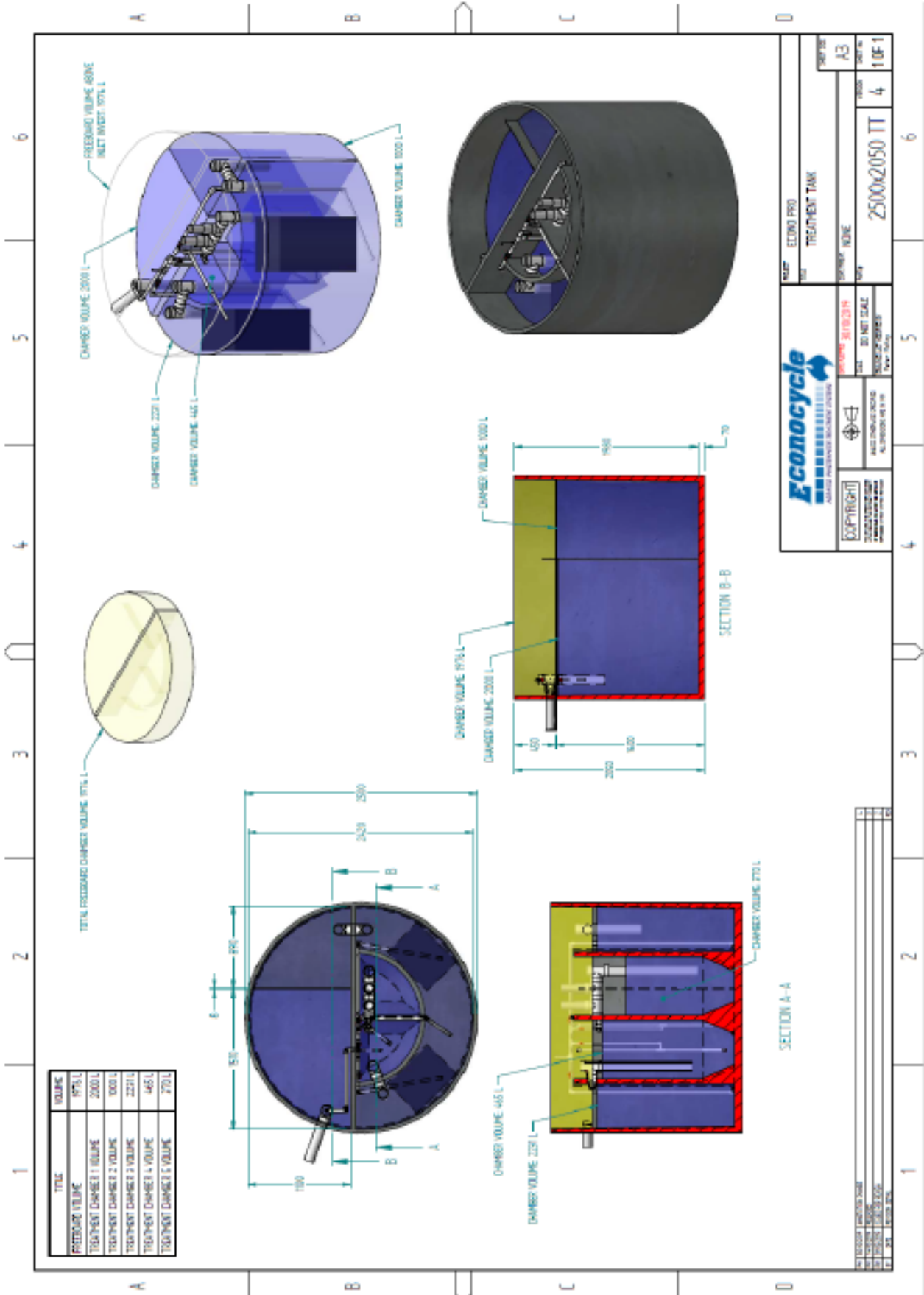

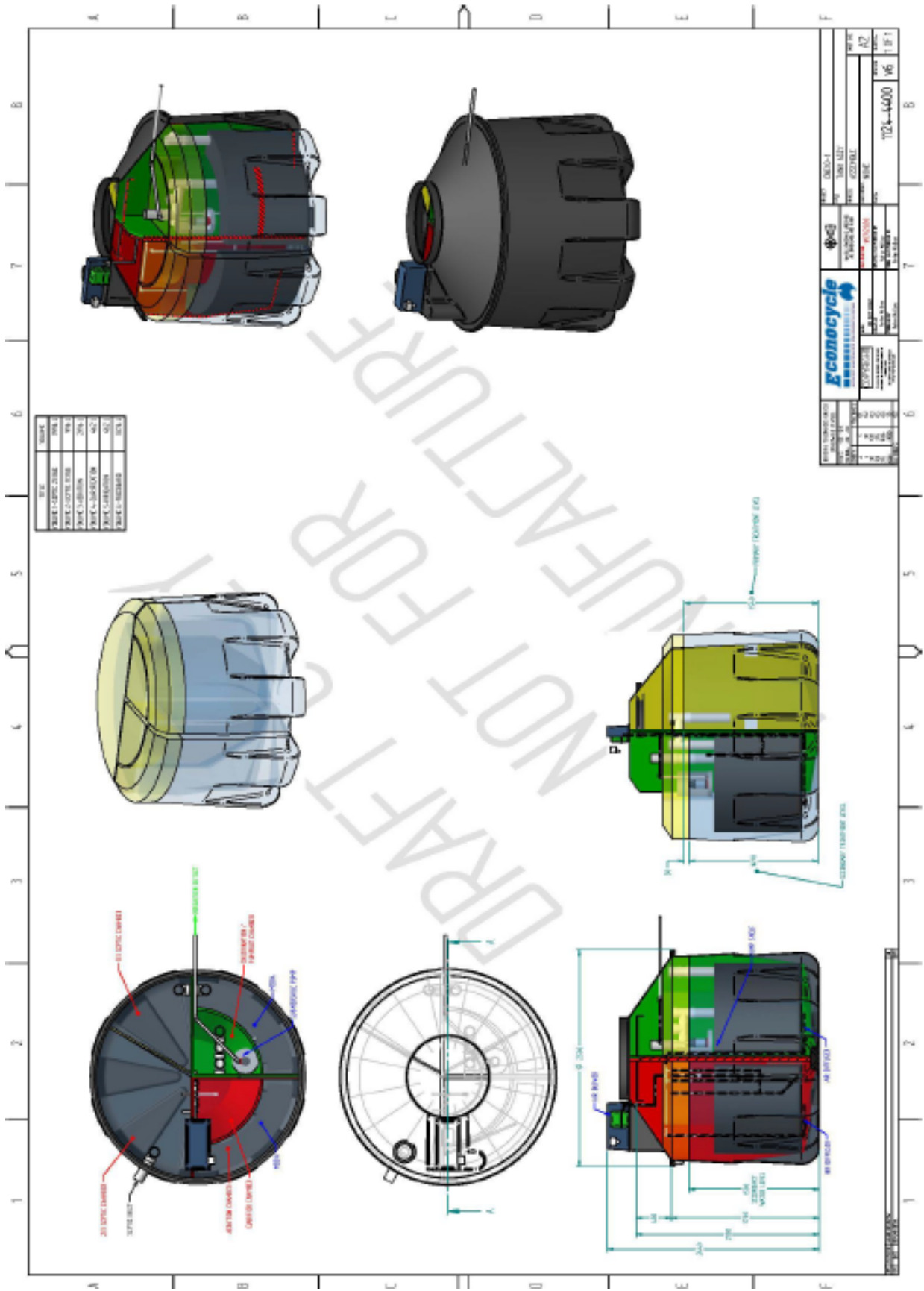



## Appendix C

### Sampling Procedure

#### Equipment Needed

***Service technician is required to provide equipment as required to facilitate sampling including:***

1. Sub surface sampler. Approx. 1.8m long with a sample taking or bottle holding device on the end. Commercial examples – Tank Sampler (Thermo Fischer), Series 6000 Jar Sampler (Ben Meadows), Grab Sampler Li (Rickly Hydrogeologic),
2. Hex drive bit and battery drill, or socket set and driver.

***Sampler / Auditor is to provide:***

1. Sterilised esky to transport the samples to the laboratory within 24hrs at a temp of less than 4 Degrees Celsius.
2. Approved Sampling bottles

#### Procedure

***Please note that steps 1-6 below will be performed by a service technician upon request by the relevant Authority conducting the sampling / auditing. The service technician is also responsible for securing all plant and equipment upon completion of the sampling / auditing.***

1. An accredited service technician unscrews and opens the motor box and effluent chamber, ensuring that there is nothing mechanically wrong with the system.
2. Turn the power to the system off at the GPO.
3. Prepare the sampler or sample bottle on the sampling stick.
4. Mark the sample pole at 1450mm from the sample inlet. Lower the sampler until the mark is level with the lip of the effluent chamber. This will ensure the sample is taken at the same level as the inlet to the irrigation pump.
5. Allow sampler or sample bottle to fill completely before raising from the sampling height.
6. Promptly fill, and or, seal the sample. Making sure not to contaminate the sample

***The Sampler / Auditor is responsible for the following steps:***

7. Label accordingly and place sample in sterilised esky at 4 degrees Celsius or lower.
8. Deliver to laboratory, complete with relevant Chain of Custody forms.
9. If further samples are required or you are sampling another plant, please sterilise equipment and repeat procedure.